

Ultrasonic Flowmeters for Liquids for Permanent Installation in Hazardous Areas

Especially designed for the stationary use in explosive atmosphere

Features

- Precise bi-directional and highly dynamic flow measurement with the non-intrusive clamp-on technology
- High precision at fast and slow flow rates, high temperature and zero point stability
- ATEXcertified FLUXUS ADM 8027 is presented in a flameproof housing (IP66) and can be operated by a magnet pen without opening the housing
- All stainless steel and seawater resistant FLUXUS ADM 8127 is ATEX certified and thus suited for offshore applications
- Automatic loading of calibration data and transducer detection for a fast and easy set-up (less than 5 min), providing precise and long-term stable results
- User-friendly design
- Transducers available for a wide range of inner pipe diameters (10...6500 mm) and fluid temperatures (-40...+400 °C)
- ATEX, IECEx approved transducers for hazardous areas available
- HybridTrek automatically switches between transit time and NoiseTrek mode of measurement when high particulate flows are encountered

Applications

- Chemical industry
- Petrochemical industry
- Oil extraction and exploration
- Natural gas extraction and processing
- Refineries



FLUXUS ADM 8027



FLUXUS ADM 8127



Measurement with transducers mounted by Variofix L

Table of Contents

Function	3
Measurement Principle	3
Calculation of Volumetric Flow Rate	3
Number of Sound Paths	4
Typical Measurement Setup	5
Flow Transmitter	6
Technical Data	6
Dimensions	9
Wall and 2 " Pipe Mounting Kit.....	10
Terminal Assignment	11
Transducers	13
Transducer Selection	13
Transducer Order Code	14
Technical Data	15
Transducer Mounting Fixture	18
Coupling Materials for Transducers	20
Connection Systems	21
Transducer Cable.....	21
Junction Box	22
Technical Data	22
Dimensions	22
2 " Pipe Mounting Kit (optional).....	23
Terminal Assignment	23

Function

Measurement Principle

Transit Time Difference Principle

In order to measure the flow of a medium in a pipe, ultrasonic signals are used, employing the transit time difference principle. Ultrasonic signals are emitted by a transducer installed on the pipe and received by a second transducer. These signals are emitted alternately in the flow direction and against it.

As the medium in which the signals propagate is flowing, the transit time of the ultrasonic signals in the flow direction is shorter than against the flow direction.

The transit time difference, Δt , is measured and allows the flowmeter to determine the average flow velocity along the propagation path of the ultrasonic signals. A flow profile correction is then performed in order to obtain the area averaged flow velocity, which is proportional to the volumetric flow rate.

Two integrated microprocessors control the entire measuring process. This allows the flowmeter to remove disturbance signals, and to check each received ultrasonic wave for its validity which reduces noise.

HybridTrek

If the gaseous or solid content in the medium increases occasionally during measurement, a measurement with the transit time difference principle is no longer possible. NoiseTrek mode will then be selected by the flowmeter. This measurement method allows the flowmeter to achieve a stable measurement even with high gaseous or solid content

The transmitter can switch automatically between transit time and NoiseTrek mode without any changes to the measurement setup.

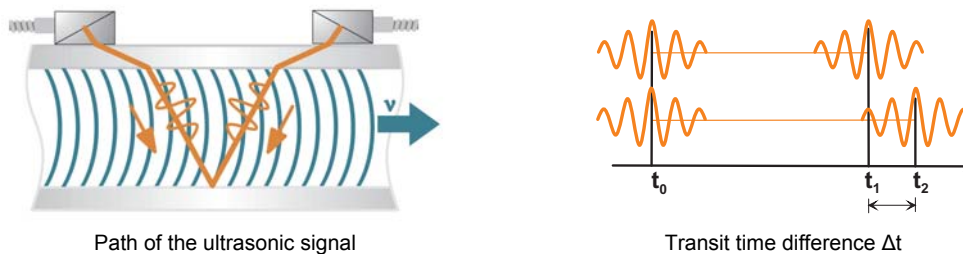

Calculation of Volumetric Flow Rate

$$\dot{V} = k_{Re} \cdot A \cdot k_a \cdot \Delta t / (2 \cdot t_{fl})$$

where

- \dot{V} - volumetric flow rate
- k_{Re} - fluid mechanics calibration factor
- A - cross-sectional pipe area
- k_a - acoustical calibration factor
- Δt - transit time difference
- t_{fl} - transit time in the medium

Number of Sound Paths

The number of sound paths is the number of transits of the ultrasonic signal through the medium in the pipe. Depending on the number of sound paths, the following methods of installation exist:

- **reflection mode**

The number of sound paths is even. Both of the transducers are mounted on the same side of the pipe. Correct positioning of the transducers is easier.

- **diagonal mode**

The number of sound paths is odd. Both of the transducers are mounted on opposite sides of the pipe. In the case of a high signal attenuation by the medium, pipe and coatings, diagonal mode with 1 sound path will be used.

The preferred method of installation depends on the application. While increasing the number of sound paths increases the accuracy of the measurement, signal attenuation increases as well. The optimum number of sound paths for the parameters of the application will be determined automatically by the transmitter.

As the transducers can be mounted with the transducer mounting fixture in reflection mode or diagonal mode, the number of sound paths can be adjusted optimally for the application.

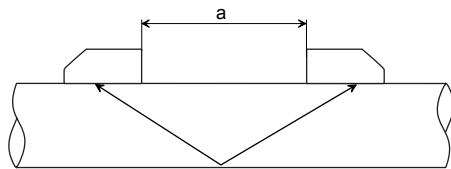

Reflection mode, number of sound paths: 2

a - transducer distance

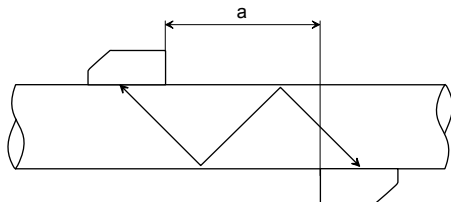

Diagonal mode, number of sound paths: 3

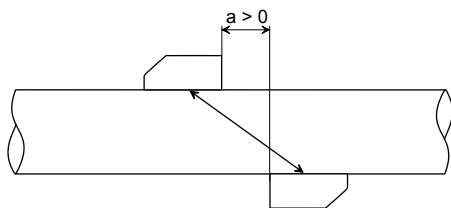

Diagonal mode, number of sound paths: 1

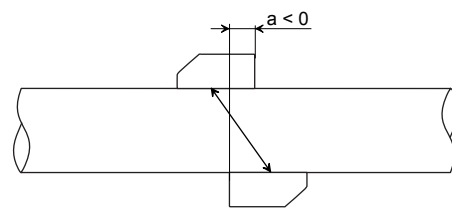

Diagonal mode, number of sound paths: 1,
negative transducer distance

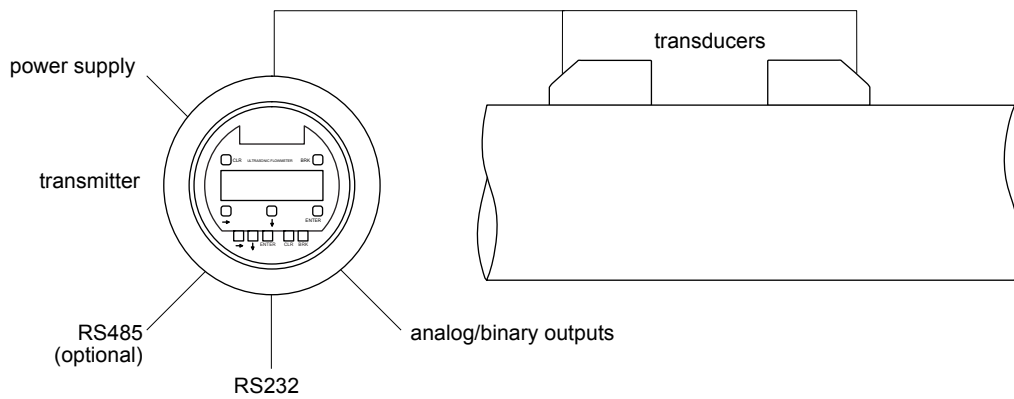

Typical Measurement Setup



Example of a measurement setup in reflection mode

Flow Transmitter

Technical Data

FLUXUS	ADM 8027 ADM 8027L ADM 8027P ADM 8027LP	ADM 8027C24 ADM 8027LC24	ADM 8127 ADM 8127P	ADM 8127C24
design	explosion proof field device		explosion proof offshore device	
				
measurement				
measurement principle	transit time difference correlation principle, automatic NoiseTrek selection for measurements with high gaseous or solid content			
flow velocity	0.01...25 m/s			
repeatability	0.15 % of reading ±0.01 m/s			
medium	all acoustically conductive liquids with < 10 % gaseous or solid content in volume (transit time difference principle)			
temperature compensation	corresponding to the recommendations in ANSI/ASME MFC-5M-1985			
accuracy¹				
with standard calibration	±1.6 % of reading ±0.01 m/s			
with extended calibration (optional)	±1.2 % of reading ±0.01 m/s			
with field calibration ²	±0.5 % of reading ±0.01 m/s			
flow transmitter				
power supply	100...240 V/50...60 Hz or 20...32 V DC or on request: 11...16 V DC	24 V DC ±10 %	100...240 V/50...60 Hz or 20...32 V DC or on request: 11...16 V DC	24 V DC ±10 %
power consumption	< 10 W	< 4 W	< 10 W	< 4 W
number of flow measuring channels	1, optional: 2	1, optional: 2	1, optional: 2	1, optional: 2
signal attenuation	0...100 s, adjustable			
measuring cycle (1 channel)	100...1000 Hz			
response time	1 s (1 channel), option: 70 ms			
housing material	cast aluminum ADM 8027, ADM 8027P, ADM 8027C24: powder coated ADM 8027L, ADM 8027LP, ADM 8027LC24: special offshore coating		stainless steel 316/316L (1.4401, 1.4404, 1.4432)	
degree of protection according to IEC/EN 60529	IP66		IP66	
dimensions	see dimensional drawing			
weight	6 kg		8.5 kg	
fixation	wall mounting, optional: 2" pipe mounting			
operating temperature	-20...+60 °C	-20...+50 °C	-20...+50 °C	-20...+50 °C
display	2 x 16 characters, dot matrix, backlight			
menu language	English, German, French, Dutch, Spanish			

¹ for transit time difference principle, reference conditions and v > 0.15 m/s

² reference uncertainty < 0.2 %

FLUXUS	ADM 8027 ADM 8027L ADM 8027P ADM 8027LP	ADM 8027C24 ADM 8027LC24	ADM 8127 ADM 8127P	ADM 8127C24	
explosion protection					
	1	1	1	1	
A T E X	zone				
	marking	ADM 8027: CE 0637 Ex II2G Ex de IIC T6 T _a -20...+60 °C ADM 8027L: CE 0637 Ex II2G Ex de IIB T6 T _a -20...+60 °C ADM 8027P: CE 0637 Ex II2G Ex de IIC T4 T _a -20...+60 °C ADM 8027LP: CE 0637 Ex II2G Ex de IIB T4 T _a -20...+60 °C	ADM 8027C24: CE 0637 Ex II2G Ex de [ib] IIC T4 T _a -20...+50 °C ADM 8027LC24: CE 0637 Ex II2G Ex de [ib] IIB T4 T _a -20...+50 °C	ADM 8127: CE 0637 Ex II2G Ex de IIC T6 T _a -20...+50 °C ADM 8127P: CE 0637 Ex II2G Ex de IIC T4 T _a -20...+50 °C	CE 0637 Ex II2G Ex de [ib] IIC T4 T _a -20...+50 °C
	certification	IBExU01ATEX1064	IBExU01ATEX1064	IBExU05ATEX1078	IBExU05ATEX1078
	type of protection	electronics compartment: flameproof enclosure connection compartment: increased safety	electronics compartment: flameproof enclosure connection compartment: increased safety output circuits: intrinsic safety	electronics compartment: flameproof enclosure connection compartment: increased safety	electronics compartment: flameproof enclosure connection compartment: increased safety output circuits: intrinsic safety
intrinsic safety parameters	-	U _m = 250 V intrinsically safe outputs: U _i = 28.2 V P _i = 0.76 W L _i , C _i negligible	-	U _m = 250 V intrinsically safe outputs: U _i = 28.2 V P _i = 0.76 W L _i , C _i negligible	
measuring functions					
physical quantities	volumetric flow rate, mass flow rate, flow velocity				
totalizer	volume, mass				
calculation functions	average, difference, sum (2 measuring channels necessary)				
diagnostic functions	sound speed, signal amplitude, SNR, SCNR, standard deviation of amplitudes and transit times				
data logger					
loggable values	all physical quantities, totalized values and diagnostic values				
capacity	> 100 000 measured values				
communication					
interface	- process integration: optional: RS485 (Modbus, emitter) or HART - diagnosis: RS232 ³	- diagnosis: RS232 ³	- process integration: optional: RS485 (Modbus, emitter) or HART - diagnosis: RS232 ³	- diagnosis: RS232 ³	
serial data kit (optional)					
software (all Windows™ versions)	- FluxData: download of measurement data, graphical presentation, conversion to other formats (e.g. for Excel™) - FluxKoef: creating medium data sets				
cable	RS232 ³				
adapter	RS232 - USB ³				

³ connection of the interface RS232 outside of explosive atmosphere (housing cover open)

FLUXUS	ADM 8027 ADM 8027L ADM 8027P ADM 8027LP	ADM 8027C24 ADM 8027LC24	ADM 8127 ADM 8127P	ADM 8127C24
outputs (optional)				
The outputs are galvanically isolated from the transmitter.				
current output				
number	1, optional: additionally 1	1	1, optional: additionally 1	1
current output I1, I2 - range - accuracy - active output	0/4...20 mA 0.1 % of reading ±15 µA ADM 8027, ADM 8027L: R _{ext} < 500 Ω	4...20 mA 0.1 % of reading ±15 µA -	0/4...20 mA 0.1 % of reading ±15 µA ADM 8127: R _{ext} < 500 Ω	4...20 mA 0.1 % of reading ±15 µA -
- passive output	ADM 8027P, ADM 8027LP: U _{ext} = 4...26.4 V, depending on R _{ext} R _{ext} < 1 kΩ	U _{ext} = 4...28.2 V, depending on R _{ext} R _{ext} < 1 kΩ intrinsic safety	ADM 8127P: U _{ext} = 4...26.4 V, depending on R _{ext} R _{ext} < 1 kΩ	U _{ext} = 4...28.2 V, depending on R _{ext} R _{ext} < 1 kΩ intrinsic safety
current output I1 in HART mode - range - passive output	4...20 mA U _{ext} = 10...24 V	- -	4...20 mA U _{ext} = 10...24 V	- -
binary output				
number	1 open collector optional: additionally 1 open collector and max. 2 Reed relays or max. 3 open collector	1	1 open collector optional: additionally 1 open collector and max. 2 Reed relays or max. 3 open collector	1
Reed relay open collector	48 V/0.25 A 24 V/4 mA	- 24 V/4 mA intrinsic safety	48 V/0.25 A 24 V/4 mA	- 24 V/4 mA intrinsic safety
binary output as alarm output - functions	limit, change of flow direction or error	limit, change of flow direction or error	limit, change of flow direction or error	limit, change of flow direction or error
binary output as pulse output - pulse value - pulse width	0.01...1000 units 1...1000 ms	0.01...1000 units 1...1000 ms	0.01...1000 units 1...1000 ms	0.01...1000 units 1...1000 ms

Dimensions

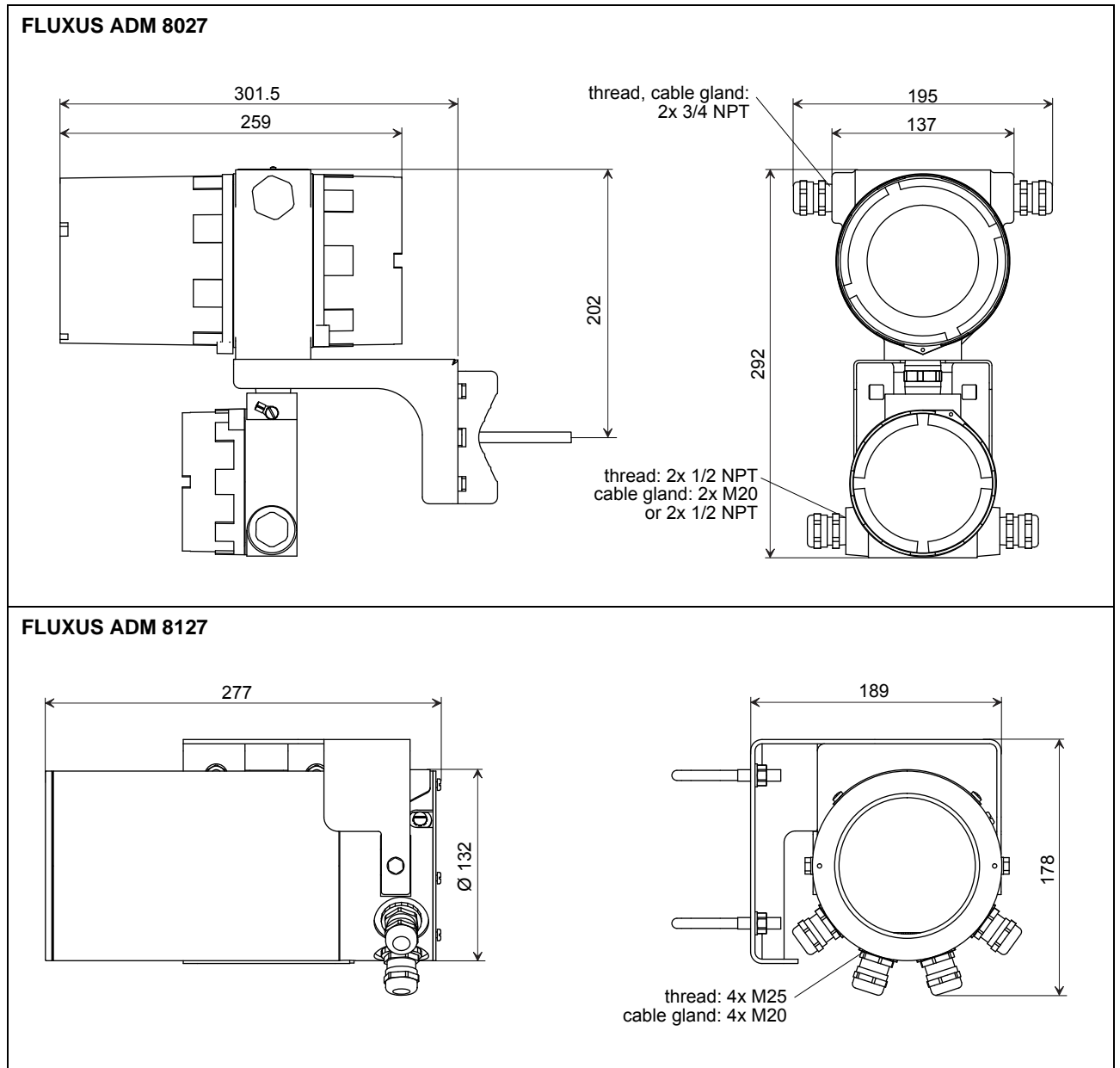

in mm

Wall and 2 " Pipe Mounting Kit

FLUXUS ADM 8027

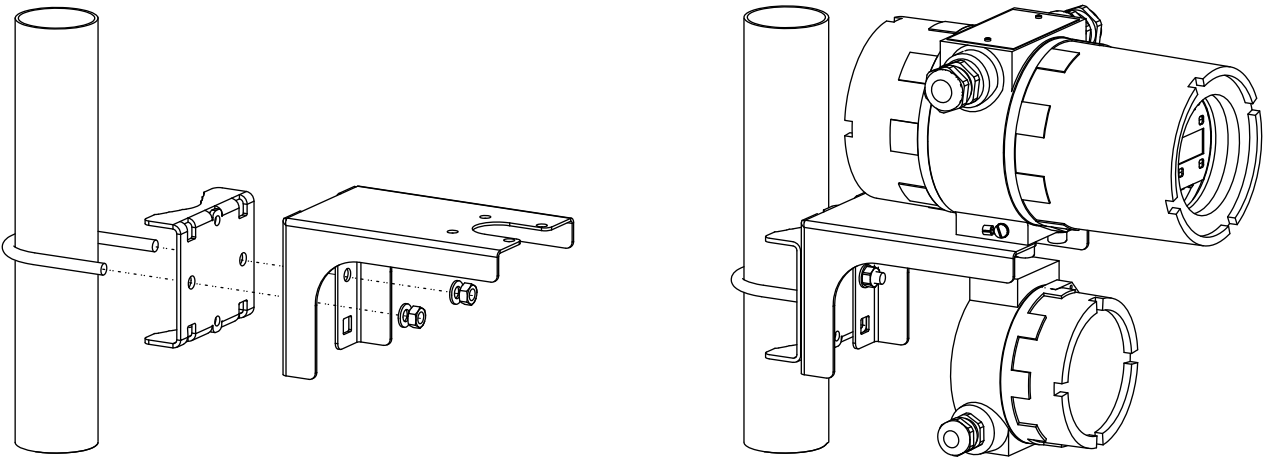

FLUXUS ADM 8127

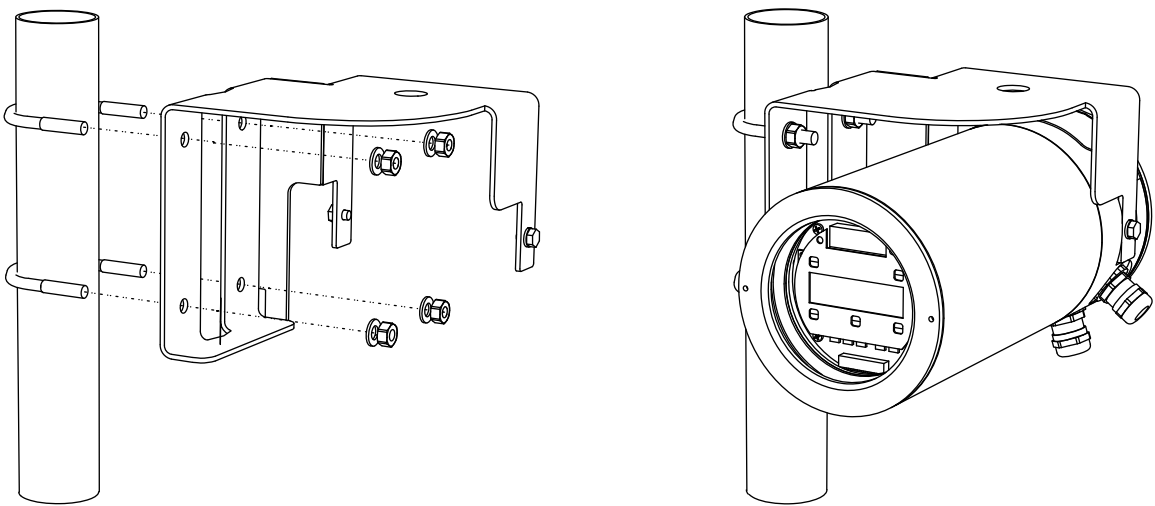

Terminal Assignment

**FLUXUS ADM 8027, ADM 8027L,
ADM 8027P, ADM 8027LP**

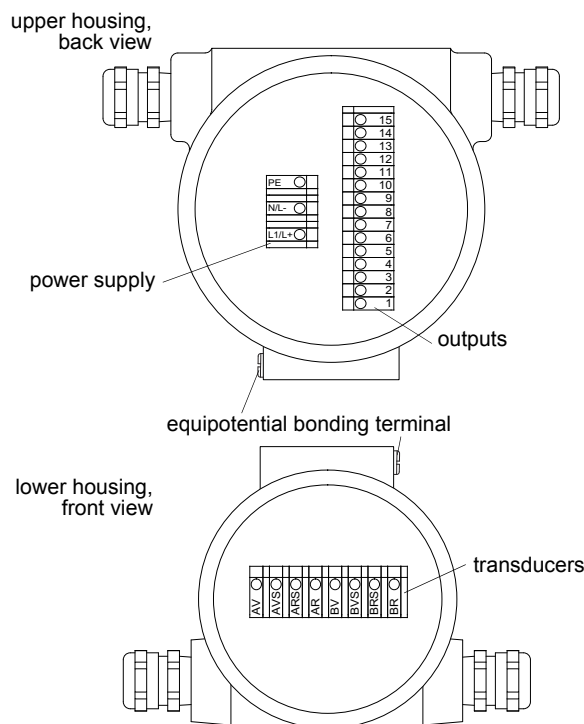

FLUXUS ADM 8127, ADM 8127P

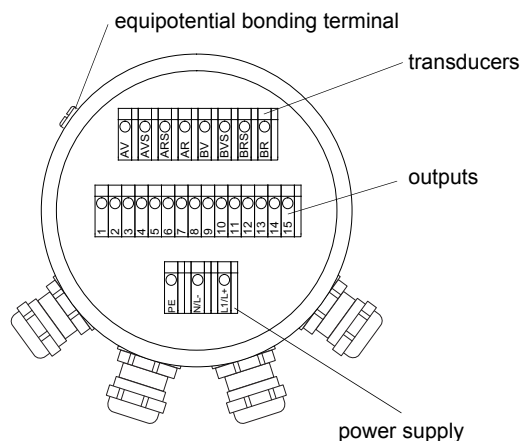

power supply

AC		DC	
terminal	connection	terminal	connection
PE	earth	PE	earth
N	neutral	L-	-
L1	phase	L+	+

transducers

measuring channel A		measuring channel B	
terminal	connection	terminal	connection
AV	transducer ↑, signal	BV	transducer ↑, signal
AVS	transducer ↑, internal shield	BVS	transducer ↑, internal shield
ARS	transducer ↗, internal shield	BRS	transducer ↗, internal shield
AR	transducer ↗, signal	BR	transducer ↗, signal
cable gland	external shield	cable gland	external shield

outputs

terminal	connection	
	ADM 8027, ADM 8027L, ADM 8027P, ADM 8027LP, ADM 8127, ADM 8127P	ADM 8027P, ADM 8127P
1(-), 2(+)	current output I1	frequency output F1
3(-), 4(+)	current output I2 (optional)	-
5(-), 6(+)	binary output B1 (open collector)	binary output B1 (open collector)
7(-), 8(+)	binary output B2 (open collector, optional)	-
9(a), 10(b)	binary output B3 (open collector or Reed relay, optional)	-
11(a), 12(b)	binary output B4 (open collector or Reed relay, optional)	-
13(B-), 14(A+)	RS485 (optional)	RS485 (optional)

FLUXUS ADM 8027C24, ADM 8027LC24

upper housing,
back view

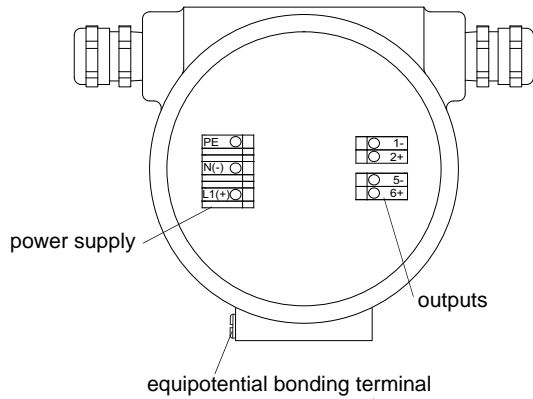

lower housing,
front view

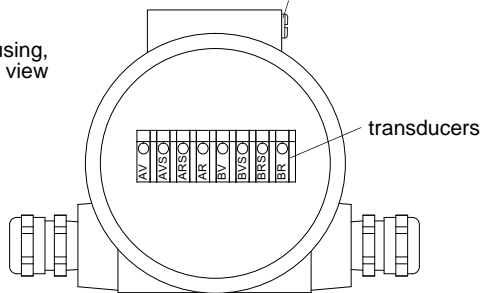



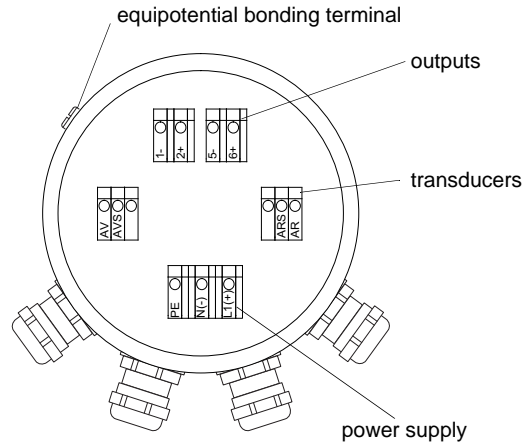

FLUXUS ADM 8127C24



power supply

DC	
terminal	connection
PE	earth
N(-)	-
L1(+)	+

transducers

measuring channel A	
terminal	connection
AV	transducer  , signal
AVS	transducer  , internal shield
ARS	transducer  , internal shield
AR	transducer  , signal
cable gland	external shield

outputs

terminal	connection
1(-), 2(+)	current output I1
5(-), 6(+)	binary output B1 (open collector)

Transducers

Transducer Selection

transducer order code

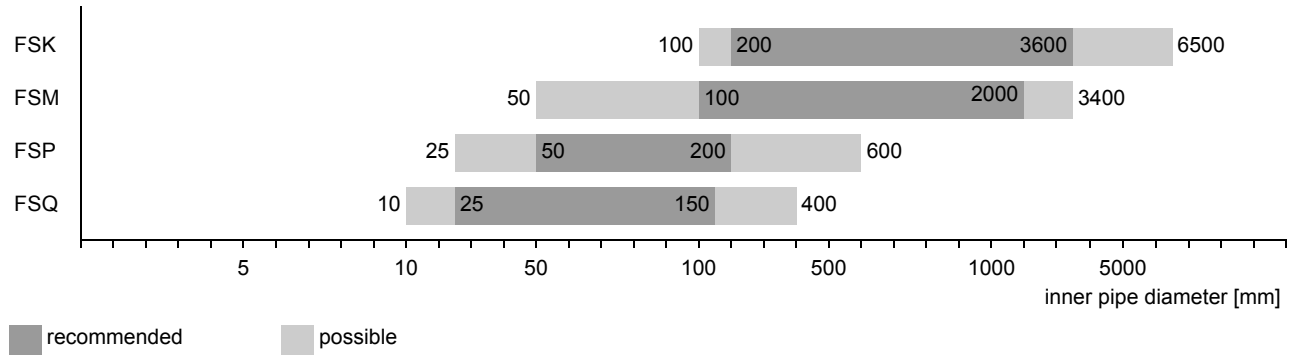





Transducer Order Code

1, 2	3	4	5, 6	7, 8	9...11	12, 13	no. of character				
transducer	transducer frequency	-	operating temperature	explosion protection	connection system	-	extension cable	/	option	description	
FS										set of ultrasonic flow transducers for liquids measurement, shear wave	
	K										0.5 MHz
	M										1 MHz
	P										2 MHz
	Q										4 MHz
		N									normal temperature range
		E									extended temperature range (shear wave transducers with transducer frequency M, P, Q)
			A1								ATEX zone 1
			I1								IECEX zone 1
				TS						direct connection or connection via junction box	
							XXX				cable length in m, for max. length of extension cable see page 21 connection system TS: 0 m: without junction box > 0 m: with junction box JB01
								IP68	degree of protection IP68		
								OS	housing with stainless steel 316		
example											
FS	M	-	N	A1	TS	-	030			shear wave transducer 1 MHz, normal temperature range, ATEX zone 1, connection system TS with junction box JB01 and extension cable 30 m	
		-				-		/			

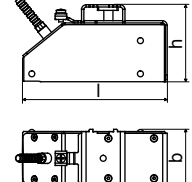
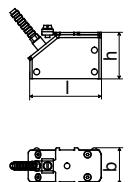
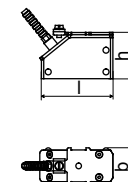
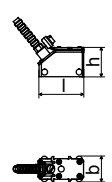
Technical Data

Shear Wave Transducers (zone 1)



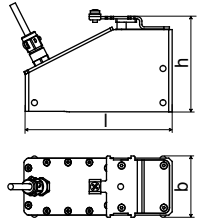
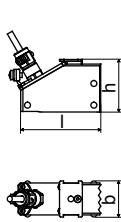
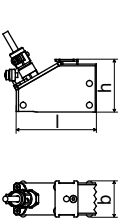

technical type		CDK1N81	CDM2N81	CDP2N81	CDQ2N81
order code		FSK-NA1TS FSK-NA1TS/OS FSK-NI1TS FSK-NI1TS/OS	FSM-NA1TS FSM-NA1TS/OS FSM-NI1TS FSM-NI1TS/OS	FSP-NA1TS FSP-NA1TS/OS FSP-NI1TS FSP-NI1TS/OS	FSQ-NA1TS FSQ-NA1TS/OS FSQ-NI1TS FSQ-NI1TS/OS
transducer frequency	MHz	0.5	1	2	4
inner pipe diameter d					
min. extended	mm	100	50	25	10
min. recommended	mm	200	100	50	25
max. recommended	mm	3600	2000	200	150
max. extended	mm	6500	3400	600	400
pipe wall thickness					
min.	mm	-	-	-	-
max.	mm	-	-	-	-
material					
housing		PEEK with stainless steel cap 304 (1.4301), option OS: 316L (1.4404)	PEEK with stainless steel cap 304 (1.4301), option OS: 316L (1.4404)	PEEK with stainless steel cap 304 (1.4301), option OS: 316L (1.4404)	PEEK with stainless steel cap 304 (1.4301), option OS: 316L (1.4404)
contact surface		PEEK	PEEK	PEEK	PEEK
degree of protection according to IEC/EN 60529		IP65	IP65	IP65	IP65
transducer cable					
type		1699	1699	1699	1699
length	m	5	4	4	3
dimensions					
length l	mm	126.5	62.5	62.5	39
width b	mm	51	32	32	22
height h	mm	67.5	40.5	40.5	25.5
dimensional drawing					
operating temperature					
min.	°C	-40	-40	-40	-40
max.	°C	+130	+130	+130	+130
temperature compensation		x	x	x	x
explosion protection					
transducer ATEX		FSK-NA1TS FSK-NA1TS/OS	FSM-NA1TS FSM-NA1TS/OS	FSP-NA1TS FSP-NA1TS/OS	FSQ-NA1TS FSQ-NA1TS/OS
transducer IECEx		FSK-NI1TS FSK-NI1TS/OS	FSM-NI1TS FSM-NI1TS/OS	FSP-NI1TS FSP-NI1TS/OS	FSQ-NI1TS FSQ-NI1TS/OS
category zone		gas: 2G dust: 2D 1 21	gas: 2G dust: 2D 1 21	gas: 2G dust: 2D 1 21	gas: 2G dust: 2D 1 21
A explosion protection temperature (pipe surface)					
min.	°C	-55	-55	-55	-55
max.	°C	+180	+180	+180	+180
marking		CE 0637  I2G I2D Ex eq II T6...T3 Ex tD A21 IP65 TX	CE 0637  I2G I2D Ex eq II T6...T3 Ex tD A21 IP65 TX	CE 0637  I2G I2D Ex eq II T6...T3 Ex tD A21 IP65 TX	CE 0637  I2G I2D Ex eq II T6...T3 Ex tD A21 IP65 TX
certification ATEX		IBExU07ATEX1168 X	IBExU07ATEX1168 X	IBExU07ATEX1168 X	IBExU07ATEX1168 X
certification IECEx		IECEX IBE 08.0007X	IECEX IBE 08.0007X	IECEX IBE 08.0007X	IECEX IBE 08.0007X
type of protection		gas: increased safety, powder filling dust: protection by enclosure	gas: increased safety, powder filling dust: protection by enclosure	gas: increased safety, powder filling dust: protection by enclosure	gas: increased safety, powder filling dust: protection by enclosure
necessary transducer mounting fixture		Variofix L or Variofix C	Variofix L or Variofix C	Variofix L or Variofix C	Variofix L or Variofix C

Shear Wave Transducers (zone 1, IP68)

technical type		CDK1LI1	CDM2LI1	CDP2LI1
order code		FSK-NA1TS/IP68 FSK-NI1TS/IP68	FSM-NA1TS/IP68 FSM-NI1TS/IP68	FSP-NA1TS/IP68 FSP-NI1TS/IP68
transducer frequency	MHz	0.5	1	2
inner pipe diameter d				
min. extended	mm	100	50	25
min. recommended	mm	200	100	50
max. recommended	mm	3600	2000	200
max. extended	mm	6500	3400	600
pipe wall thickness				
min.	mm	-	-	-
max.	mm	-	-	-
material				
housing		PEEK with stainless steel cap 316Ti (1.4571)	PEEK with stainless steel cap 316Ti (1.4571)	PEEK with stainless steel cap 316Ti (1.4571)
contact surface		PEEK	PEEK	PEEK
degree of protection according to IEC/EN 60529		IP68 ¹	IP68 ¹	IP68 ¹
transducer cable				
type		2550	2550	2550
length	m	12	12	12
dimensions				
length l	mm	128.5	70	70
width b	mm	54	32	32
height h	mm	83.5	46	46
dimensional drawing				
operating temperature				
min.	°C	-40	-40	-40
max.	°C	+100	+100	+100
temperature compensation		x	x	x
explosion protection				
transducer ATEX		FSK-NA1TS/IP68	FSM-NA1TS/IP68	FSP-NA1TS/IP68
transducer IECEx		FSK-NI1TS/IP68	FSM-NI1TS/IP68	FSP-NI1TS/IP68
category		gas: 2G dust: 2D	gas: 2G dust: 2D	gas: 2G dust: 2D
zone		1 21	1 21	1 21
ATEX / IECEx explosion protection				
min.	°C	-55	-55	-55
max.	°C	+180	+180	+180
marking		CE 0637 Ex II 2G II2D Ex q II T6...T3 Ex tD A21 IP68 TX	CE 0637 Ex II 2G II2D Ex q II T6...T3 Ex tD A21 IP68 TX	CE 0637 Ex II 2G II2D Ex q II T6...T3 Ex tD A21 IP68 TX
certification ATEX		IBExU07ATEX1168 X	IBExU07ATEX1168 X	IBExU07ATEX1168 X
certification IECEx		IECEX IBE 08.0007X	IECEX IBE 08.0007X	IECEX IBE 08.0007X
type of protection		gas: powder filling dust: protection by enclosure	gas: powder filling dust: protection by enclosure	gas: powder filling dust: protection by enclosure
necessary transducer mounting fixture		Variofix L or Variofix C	Variofix L or Variofix C	Variofix L or Variofix C

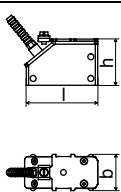
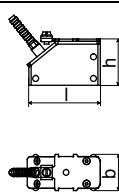
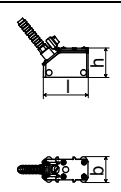
¹ test conditions: 3 months/2 bar (20 m)/20 °C

Shear Wave Transducers (zone 1, extended temperature range)

technical type		CDM2E85	CDP2E85	CDQ2E85
order code		FSM-EA1TS FSM-EA1TS/OS FSM-EI1TS FSM-EI1TS/OS	FSP-EA1TS FSP-EA1TS/OS FSP-EI1TS FSP-EI1TS/OS	FSQ-EA1TS FSQ-EA1TS/OS FSQ-EI1TS FSQ-EI1TS/OS
transducer frequency	MHz	1	2	4
inner pipe diameter d				
min. extended	mm	50	25	10
min. recommended	mm	100	50	25
max. recommended	mm	2000	200	150
max. extended	mm	3400	600	400
pipe wall thickness				
min.	mm	-	-	-
max.	mm	-	-	-
material				
housing		PI with stainless steel cap 304 (1.4301), option OS: 316L (1.4404)	PI with stainless steel cap 304 (1.4301), option OS: 316L (1.4404)	PI with stainless steel cap 304 (1.4301), option OS: 316L (1.4404)
contact surface		PI	PI	PI
degree of protection according to IEC/EN 60529		IP56	IP56	IP56
transducer cable				
type		6111	6111	6111
length	m	4	4	3
dimensions				
length l	mm	62.5	62.5	39
width b	mm	32	32	22
height h	mm	40.5	40.5	25.5
dimensional drawing				
operating temperature				
min.	°C	-30	-30	-30
max.	°C	+200	+200	+200
temperature compensation		x	x	x
explosion protection				
A T E X / I E C E x	transducer ATEX	FSM-EA1TS FSM-EA1TS/OS	FSP-EA1TS FSP-EA1TS/OS	FSQ-EA1TS FSQ-EA1TS/OS
	transducer IECEx	FSM-EI1TS FSM-EI1TS/OS	FSP-EI1TS FSP-EI1TS/OS	FSQ-EI1TS FSQ-EI1TS/OS
	category zone	gas: 2G dust: 3D 1 22	gas: 2G dust: 3D 1 22	gas: 2G dust: 3D 1 22
explosion protection temperature (pipe surface)				
min.	°C	-45	-45	-45
max.	°C	+225	+225	+225
marking		CE 0637  II2G II3D Ex eq II T6...T2 Ex tD A22 IP56 TX	CE 0637  II2G II3D Ex eq II T6...T2 Ex tD A22 IP56 TX	CE 0637  II2G II3D Ex eq II T6...T2 Ex tD A22 IP56 TX
certification ATEX		IBExU07ATEX1168 X	IBExU07ATEX1168 X	IBExU07ATEX1168 X
certification IECEx		IECEx IBE 08.0007X	IECEx IBE 08.0007X	IECEx IBE 08.0007X
type of protection		gas: increased safety, powder filling dust: protection by enclosure	gas: increased safety, powder filling dust: protection by enclosure	gas: increased safety, powder filling dust: protection by enclosure
necessary transducer mounting fixture		Variofix L or Variofix C	Variofix L or Variofix C	Variofix L or Variofix C

Transducer Mounting Fixture

Order Code

1, 2	3	4	5	6	7...9	10, 11	no. of character			
transducer mounting fixture	transducer	-	measuring mode	size	-	fixation	outer pipe diameter	/	option	description
VL										Variofix L
VC										Variofix C
WI										transducer clamping fixture for WaveInjector
	K									transducers with transducer frequency K
	M									transducers with transducer frequency M, P
	Q									transducers with transducer frequency Q
	S									transducers with transducer frequency S
			D							reflection mode or diagonal mode
			R							reflection mode
				S						small
				M						medium
				L						large
						S				tension straps
						W				welding
						N				without fixation
							002			10...20 mm
							004			20...40 mm
							T36			40...360 mm
							013			10...130 mm
							036			130...360 mm
							092			360...920 mm
							200			920...2000 mm
							450			2000...4500 mm
							940			4500...9400 mm
							NDR			any
									IP68	degree of protection IP68
									OS	housing with stainless steel 316
									Z	special design
example										
VL	M	-	D	S	-	S	200			Variofix L and tension straps for transducers with transducer frequency M, P
		-			-			/		

Variofix L (VL)

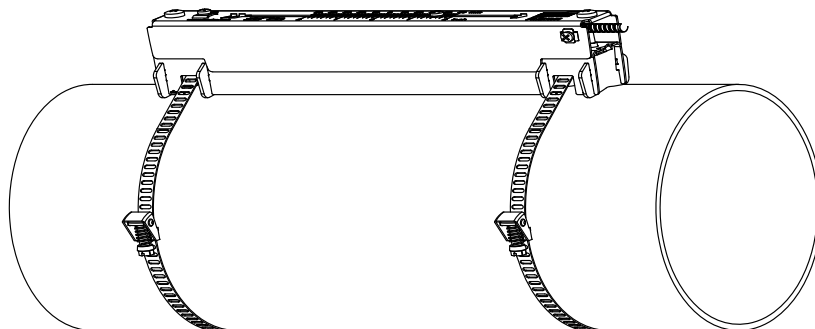

material: stainless steel 304 (1.4301), 301 (1.4310)
option OS: 316 (1.4571), 316L (1.4404), 17-7PH (1.4568)

inner length:
VLK: 348 mm,
option IP68: 368 mm
VLM: 234 mm
VLQ: 176 mm

dimensions:
VLK: 423 x 90 x 93 mm,
option IP68: 443 x 94 x 105 mm
VLM: 309 x 57 x 63 mm
VLQ: 247 x 43 x 47 mm

Variofix C (VC)

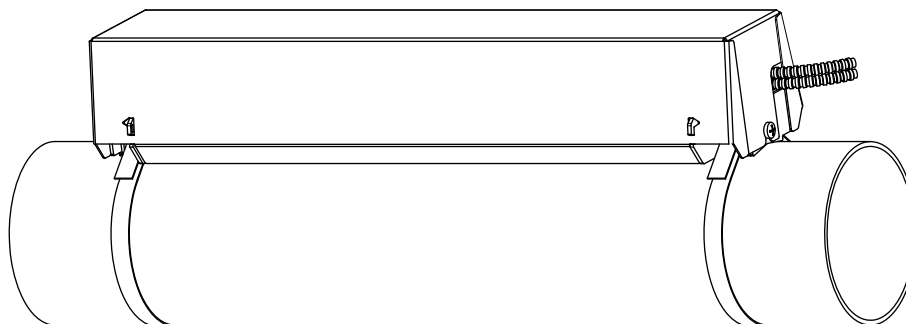

material: stainless steel 304 (1.4301), 301 (1.4310)
option OS: 316 (1.4571)

inner length:
VCK-*L: 500 mm
VCK-*S: 350 mm
VCM: 400 mm
VCQ: 250 mm

dimensions:
VCK-*L: 560 x 122 x 102 mm,
option IP68: 560 x 126 x 120 mm
VCK-*S: 410 x 122 x 102 mm,
option IP68: 410 x 126 x 120 mm
VCM: 460 x 96 x 80 mm
VCQ: 310 x 85 x 62 mm

transducer clamping fixture for Wavelnjector WI

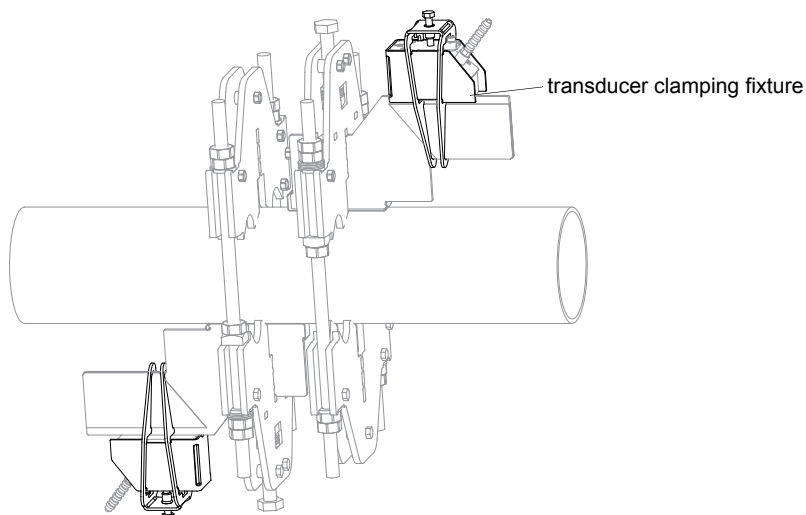

see Technical Specification
TSWavelnjectorVx-x

Coupling Materials for Transducers

		normal temperature range (4th character of transducer order code = N)		extended temperature range (4th character of transducer order code = E)		WaveInjector WI-400	
		< 100 °C	100...170 °C	< 150 °C	150...200 °C	< 280 °C	280...400 °C
< 2 h		coupling compound type N	coupling compound type E	coupling compound type E	coupling compound type E or H	coupling foil type A	coupling foil type B
< 24 h		coupling compound type N	coupling compound type E	coupling compound type E	coupling foil type VT	coupling foil type A	coupling foil type B
long time measurement	indoor	coupling compound type N	coupling compound type E	coupling foil type VT ¹	coupling foil type VT ²	coupling foil type A	coupling foil type B
	outdoor	coupling foil type VT	coupling foil type VT	coupling foil type VT ¹	coupling foil type VT ²	coupling foil type A	coupling foil type B

¹ < 5 years

² < 6 months

Technical Data

type	Order Code	operating temperature °C	material	remark
coupling compound type N	990739-1	-30...+130	mineral grease paste	
coupling compound type E	990739-2	-30...+200	silicone paste	
coupling compound type H	990739-3	-30...+250	fluoropolymer paste	
coupling foil type A	990739-7	max. 280	plomb	
coupling foil type B	990739-8	> 280...400	silver	
coupling foil type VT	990739-0	-10...+150, short-time peak max. 200	fluoroelastomer	for transducers with transducer frequency G, H, K
	990739-6			for shear wave transducers with transducer frequency M, P
	990739-14			for shear wave transducers IP68 and Lambwave transducers with transducer frequency M, P
	990739-15			for shear wave transducers with transducer frequency Q
	990739-5			for Lambwave transducers with transducer frequency Q

Connection Systems

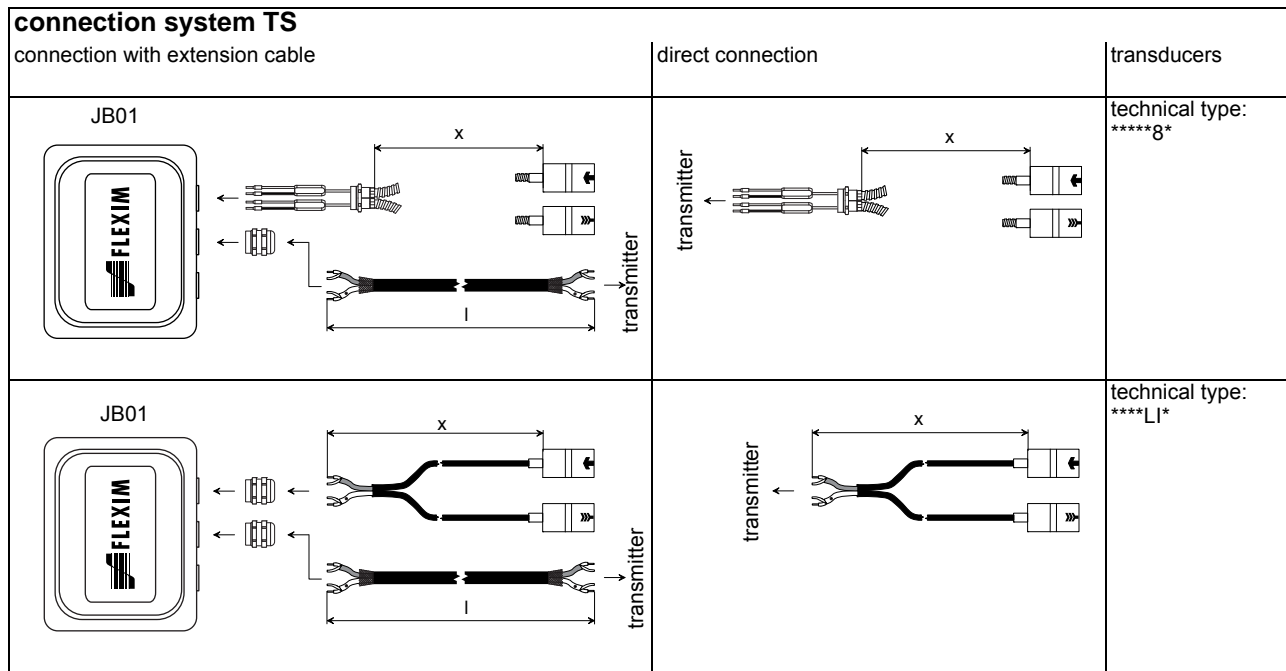

transducer frequency (3d character of transducer order code)		G, H, K		M, P		Q		S		
T S	cable length	m	x	l	x	l	x	l	x	l
	cable length (option LC)	m	5	≤ 300	4	≤ 300	3	≤ 90	2	≤ 40
	cable length (option IP68)	m	9	≤ 300	-	-	-	-	-	-
		m	12	≤ 300	12	≤ 300	-	-	-	-

x - transducer cable length
l - max. length of extension cable

Transducer Cable

Technical Data

		transducer cable			extension cable	
type		1699	2550	6111	2615	
standard length	m	see table above		12	see table above	
max. length	m	-	-	-	see table above	
operating temperature	°C	-55...+200		-40...+100	-100...+225	
properties			longitudinal water tight		halogen free fire propagation test according to IEC 60332-1 combustion test according to IEC 60754-2	
sheath						
material		stainless steel 304 (1.4301) option OS: 316L (1.4404)		-	stainless steel 304 (1.4301) option OS: 316L (1.4404)	
outer diameter	mm	8		-	8	
cable jacket						
material		PTFE		PUR	PFA	
outer diameter	mm	2.9		5.2 ±0.2	2.7	
thickness	mm	0.3		0.9	0.5	
color		brown		gray	white	
shield	x	x		x	x	

Junction Box

Technical Data

technical type	JB01S4E3M	
dimensions	see dimensional drawing	
fixation	wall mounting, optional: 2 " pipe mounting	
material		
housing	stainless steel 316L (1.4404)	
gasket	silicone	
degree of protection according to IEC/ EN 60529	IP67	
operating temperature		
min.	°C	-40
max.	°C	+80
explosion protection		
A	zone	1
T	marking	CE 0637 Ex II2G II2D Ex e mb II (T6)...T4 Ta -40...+(70)80 °C Ex tD A21 IP67 T 100 °C
E	certification ATEX	IBExU06ATEX1161
X	certification IECEx	IECEX IBE 08.0006
/	type of protection	gas: • increased safety • decoupled network: encapsulation dust: protection by enclosure
I		
E		
C		
E		
x		

Dimensions

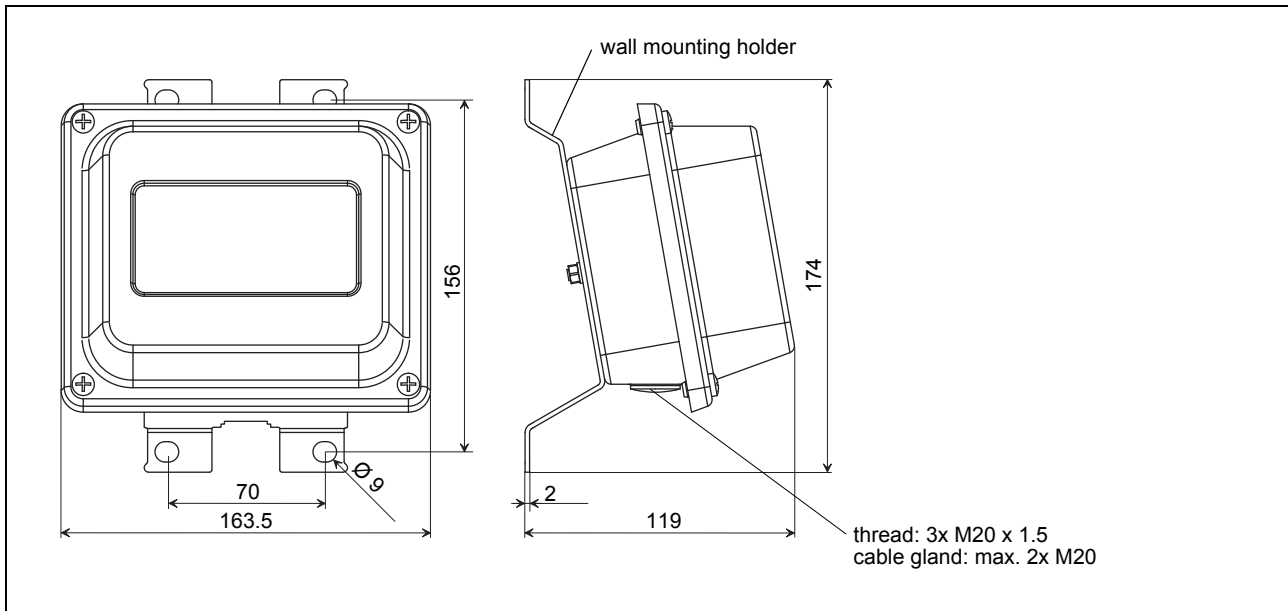

in mm

2 " Pipe Mounting Kit (optional)

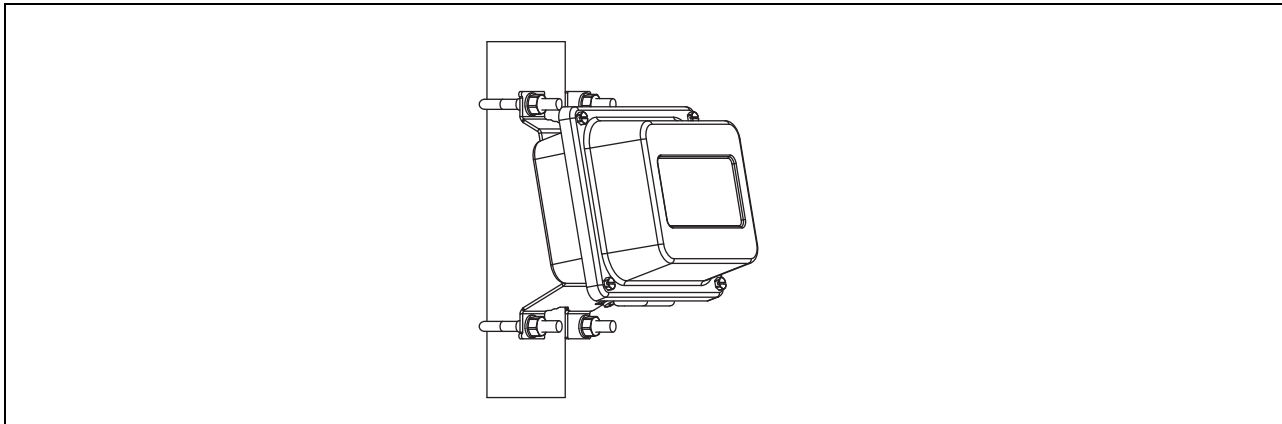

Terminal Assignment

JB01

transducers

terminal strip KL1

terminal	connection
V	transducer signal
VS	transducer internal shield
RS	transducer internal shield
R	transducer signal
cable gland	external shield

extension cable

terminal strip KL2

terminal	connection
TV	signal
TVS	internal shield
TRS	internal shield
TR	signal
shield terminal	external shield



FLEXIM GmbH
Wolfener Str. 36
12681 Berlin
Germany
Tel.: +49 (30) 93 66 76 60
Fax: +49 (30) 93 66 76 80

internet: www.flexim.com
e-mail: info@flexim.com

Subject to change without notification. Errors excepted.
FLUXUS® is a registered trademark of FLEXIM GmbH.
TSFLUXUS_F8V1-5EN_Leu, 2011-09-29